

**Universal multibench / premium version**  
with an extendable work frame  
**CODE: USTM\_D90**

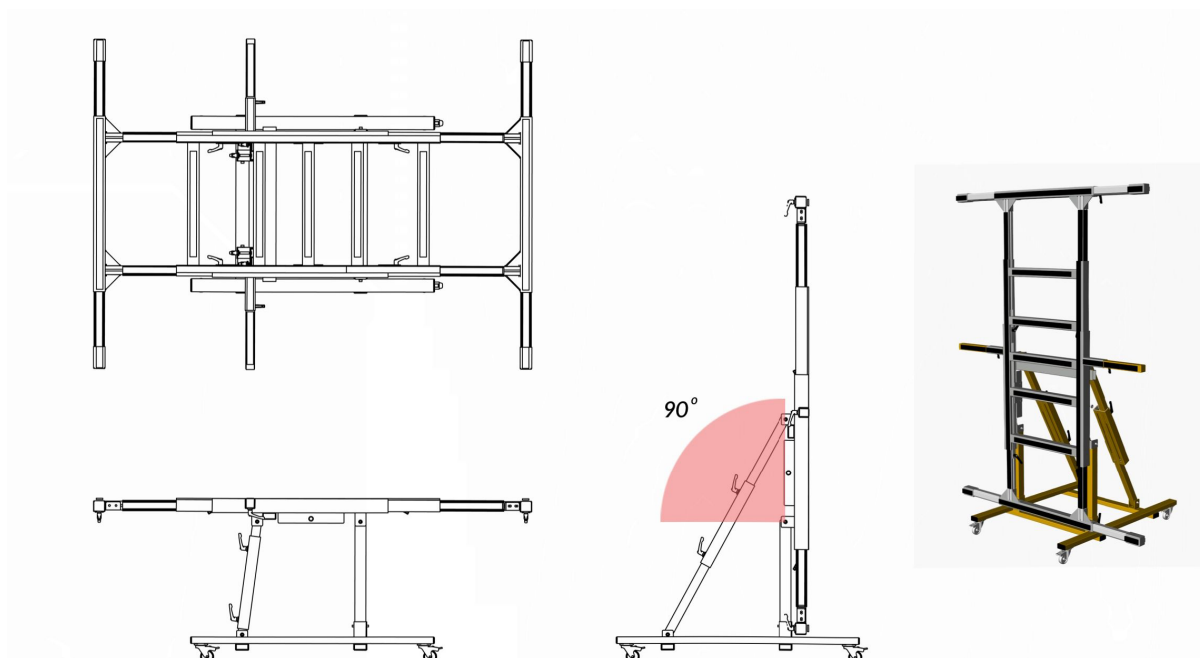

Description	Value	Colour / Quantity included
1 Work frame: dimension / when extended	1000x 1500/ 1500x2000 mm	Ral 7035
2 Work surface height	750 mm	
3 Bench weight	70 kg	
4 Allowable uniform load in horizontal position	200 kg	
5 Allowable uniform load in vertical position	150 kg	
6 Work frame supports: fixed / movable		Ral 1021; 2/1
7 Work frame tilt angle	0-90 degrees	
8 1000 mm roller table unit installation compatible	Yes	None
9 Wheeled base: fixed / with lock	Yes	Ral 1021; 2/2
10 Detachable wheeled base	Yes	
11 Baseplates can be secured with retaining brackets / straight fixtures / corner fixtures	Yes	2+2 + 2
12 Additional side support	Yes	2
13 The work frame has to be moved when tilted to 90 degrees	Yes	

**Product of the BULKON group – see more at [www bulkon.pl](http://www.bulkon.pl) / info: [biuro@bulkon.pl](mailto:biuro@bulkon.pl)**  
Company: Borucki Studio Design ul. Jakuba Goyki 10A/4 81-715 Sopot / [www.boruckidesign.com](http://www.boruckidesign.com)  
We keep on developing the usability of our products, so their details may differ from those presented in the catalogue.